

1. SCOPE

This specification shall cover the characteristics of 1-port SAW resonator with YSR315S321 used for remote-control security.

2. ELECTRICAL SPECIFICATION

2.1 Maximum Rating

DC Voltage VDC	10V
AC Voltage Vpp	10V 50Hz/60Hz
Operation temperature	-40°C to +85°C
Storage temperature	-45°C to +85°C
Max Input Power	10dBm

2.2 Electronic Characteristics

Item	Unites	Minimum	Typical	Maximum	
Center Frequency	MHz	314.925	315.000	315.075	
Insertion Loss	dB		1.4	1.9	
Quality Factor	Unload Q	8000	12800		
	50Ω Loaded Q	1000	2000		
Temperature	Turnover Temperature	°C	10	25	40
Stability	Freq.temp.Coefficient	ppm/°C		0.032	
Frequency Aging		ppm/yr		<±10	
DC. Insulation Resistance	MΩ	1.0			
Transducer Static Capacitance C0	pF		2.13		

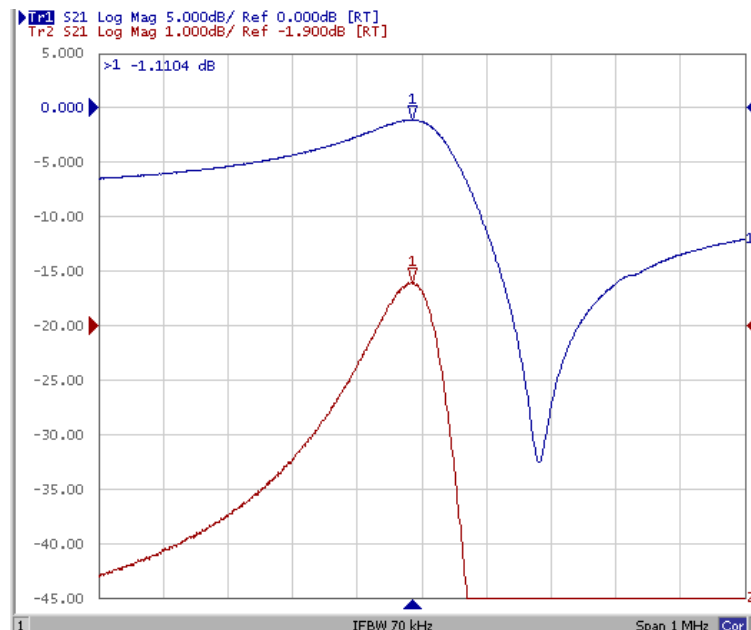

2.3 Equivalent LC Model

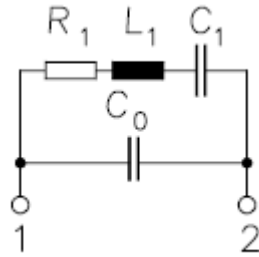

3. TEST CIRCUIT

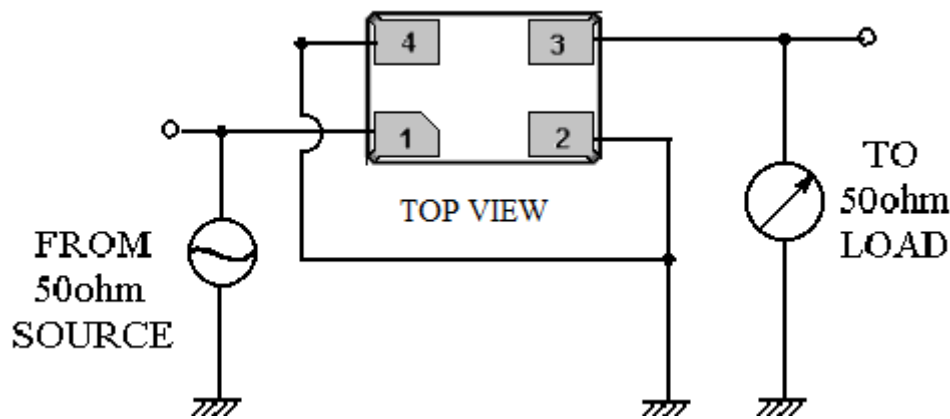

4. DIMENSION

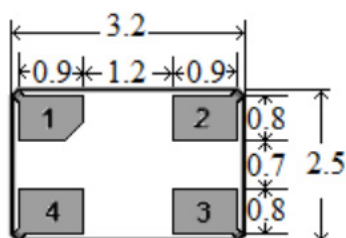
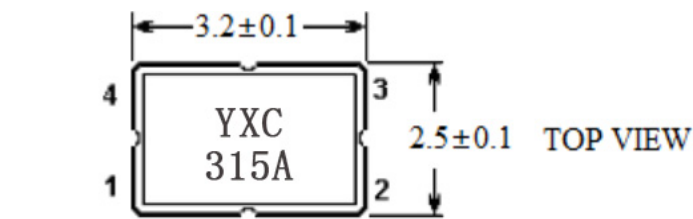

BOTTOM VIEW

Pin configuration

- 3. Input/Output
- 1. Output/Input
- 2,4. Ground

5. ENVIRONMENT CHARACTERISTIC

5-1 High temperature exposure

Subject the device to +85°C for 16 hours. Then release the filter into the room conditions for 24 hours prior to the measurement. It shall fulfill the specifications in 2-2.

5-2 Low temperature exposure

Subject the device to -40°C for 16 hours. Then release the device into the room conditions for 24 hours prior to the measurement. It shall fulfill the specifications in 2-2.

5-3 Temperature cycling

Subject the device to a low temperature of -40°C for 30 minutes. Following by a high temperature of +85°C for 30 Minutes. Then release the device into the room conditions for 24 hours prior to the measurement. It shall meet the specifications in 2-2.

5-4 Resistance to solder heat

Dip the device terminals no closer than 1.5mm into the solder bath at 260°C $\pm 10^\circ\text{C}$ for 10 ± 1 sec. Then release the device into the room conditions for 4 hours. The device shall meet the specifications in 2-2.

5-5 Solderability

Subject the device terminals into the solder bath at 245°C $\pm 5^\circ\text{C}$ for 5s, More than 95% area of the terminals must be covered with new solder. It shall meet the specifications in 2-2.

5-6 Mechanical shock

Drop the device randomly onto the concrete floor from the height of 1m 3 times. the device shall fulfill the specifications in 2-2.

5-7 Vibration

Subject the device to the vibration for 1 hour each in x,y and z axes with the amplitude of 1.5 mm at 10 to 55 Hz. The device shall fulfill the specifications in 2-2.

6. REMARK

6.1 Static voltage

Static voltage between signal load & ground may cause deterioration & destruction of the component. Please avoid static voltage.

6.2 Ultrasonic cleaning

Ultrasonic vibration may cause deterioration & destruction of the component. Please avoid ultrasonic cleaning

6.3 Soldering

Only leads of component may be soldered. Please avoid soldering another part of component.

7. PACKING

7.1 Dimensions

- (1) Carrier Tape: Figure 1
- (2) Reel: Figure 2
- (3) The product shall be packed properly not to be damaged during transportation and storage.

7.2 Reeling Quantity

- 1000 pcs/reel 7"
- 3000 pcs/reel 13"

7.3 Taping Structure

- (1) The tape shall be wound around the reel in the direction shown below.

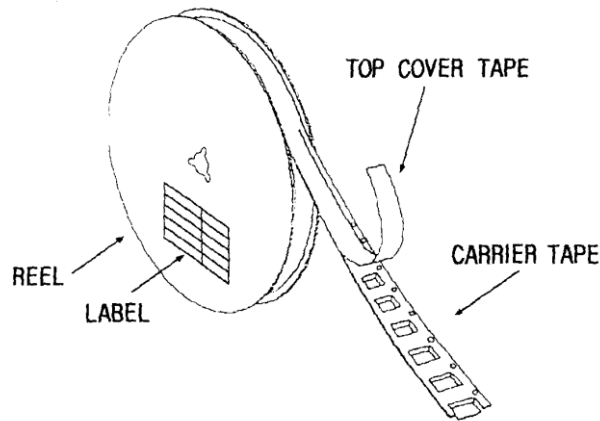

- (2) Label

Device Name	
User Product Name	
Quantity	
Lot No.	

- (3) Leader part and vacant position specifications.

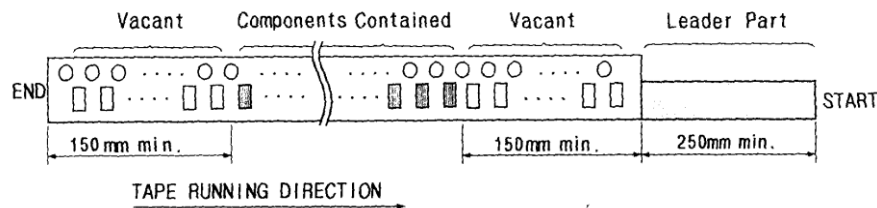

8. TAPE SPECIFICATIONS

8.1 Tensile Strength of Carrier Tape: 4.4N/mm width

8.2 Top Cover Tape Adhesion (See the below figure)

- (1) pull off angle: 0~15°
- (2) speed: 300mm/min.
- (3) force: 20~70g

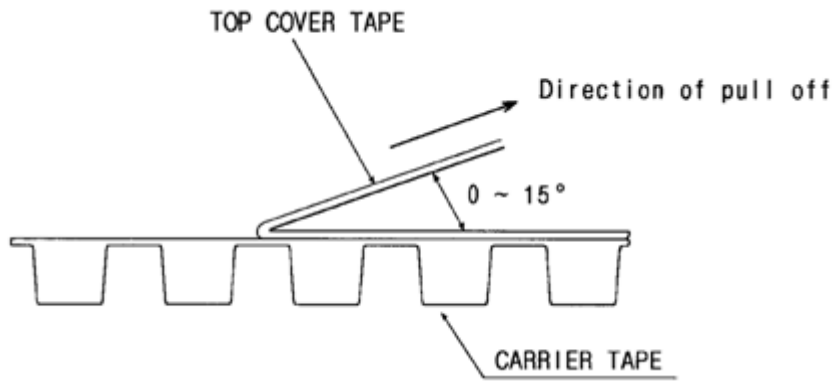

[Figure 1] Carrier Tape Dimensions

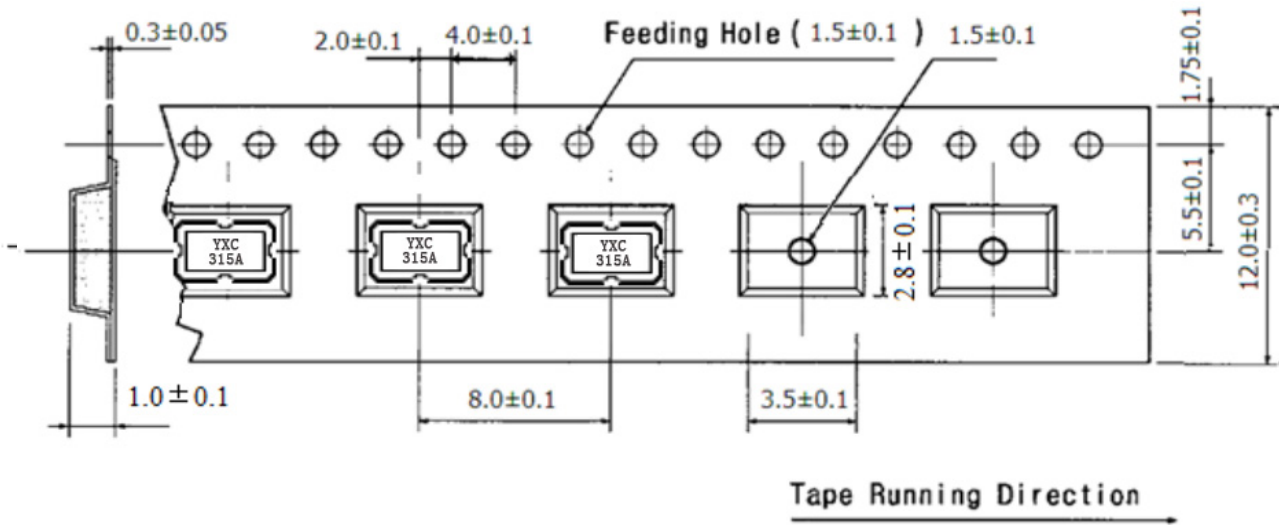

[Figure 2] 1000 pcs/reel

